

# PHOTOELECTRIC DETECTORS INSTALLATION INSTRUCTIONS

NR30TM  
NR60TM  
NR90TM

## 1 BEAM SPREAD

As the beam has spreads, an optical path is formed when it is reflected against the nearby (highly reflective) wall or the like, thereby alarm output may be prevented even if the beam from the transmitter to the receiver is interrupted. When a multiple number of detectors are installed, the beam from another detector may affect and cause malfunction. The beam spread angle of this unit is about  $\pm 1^\circ$ . Refer to the figure and table below to determine the installation position and distance to be used when installing a multiple number of units.

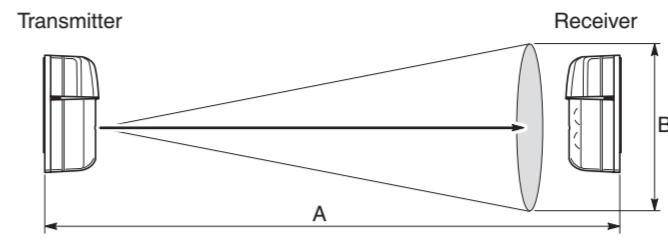

Distance and (approximate) beam spread

Distance A	Beam spread width B
15m	0.5m
30m	1.0m
60m	2.0m
90m	3.0m
120m	4.0m
180m	6.0m

## 2 PART NAMES AND FUNCTIONS

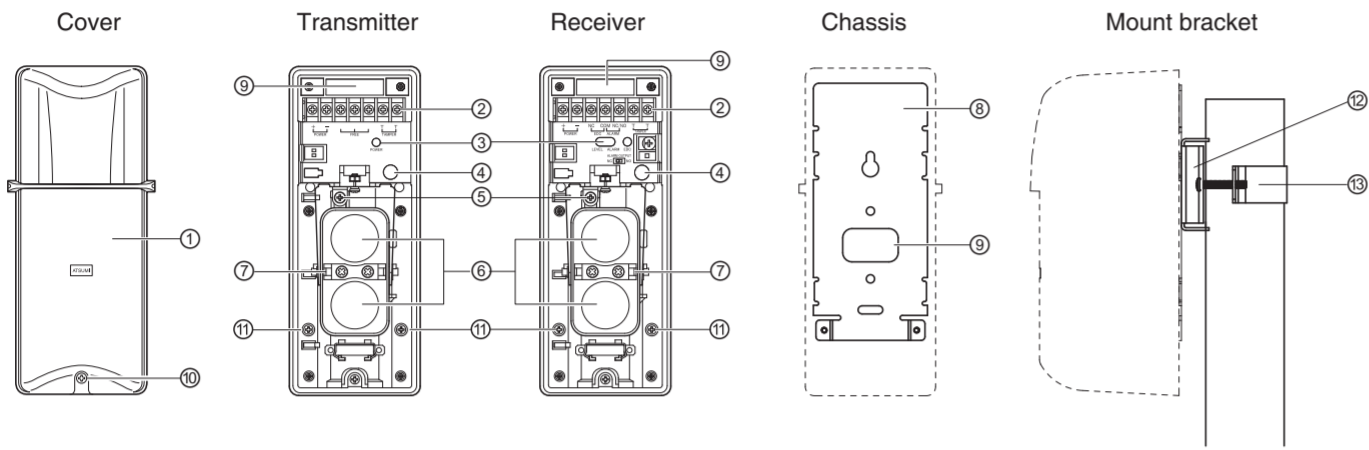

- Cover**  
Passes the near infrared ray and attenuates the visible ray.
- Wiring terminal**  
Input/output terminals for wiring to the controller
- Operation section**
  - Transmitter**
    - (1) Power supply LED  
Indicates the power input state.
  - Receiver**
    - (2) Tester level check terminal  
Used to check the optical axis alignment with a tester.
    - (3) Alarm LED  
Indicates the alarm state.
    - (4) Level LED  
By lighting on or off.
    - (5) EDC LED  
Indicates the EDC state.  
EDC sends EDC signal when it becomes difficult to maintain stable operation for more than 10 seconds due to environmental disturbance like fog or rain.
    - (6) Beam interruption time adjustment volume  
Used to determine the detection sensitivity.
- Tamper switch**  
Detects open/close of the cover.
- Vertical adjustment screw**  
Used to make fine adjustment of optical axis vertically.
- Twin lens**  
Lenses to transmit and receive the infrared beam.
- Scope**  
Used to make rough adjustment of the optical axis alignment.
- Chassis**  
Used to install the main unit to the wall or pole.
- Wire hole**  
Used for wiring.
- Cover fixing screws**  
Used to fix the cover.
- Chassis fixing screws**  
Used to install the main unit to the chassis.
- Mount plate**  
Used to mount the chassis to the pole.
- Mount bracket**  
Used to mount the chassis to the pole.

Operation section of transmitter

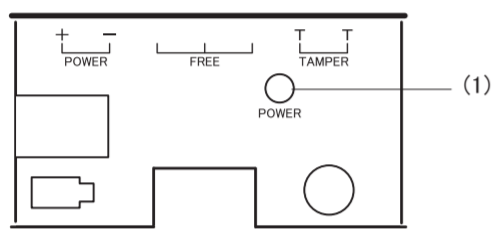

Operation section of receive

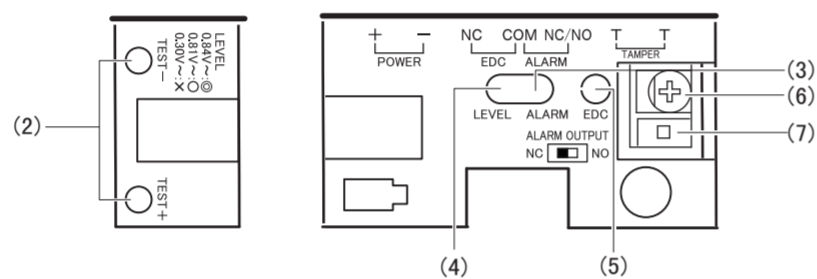

## 3 WIRING

### 1. Terminal Arrangement

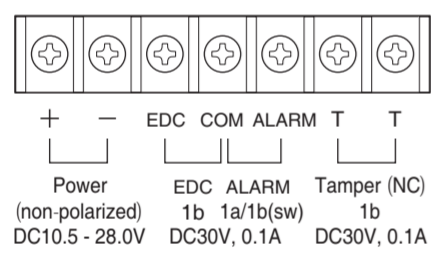
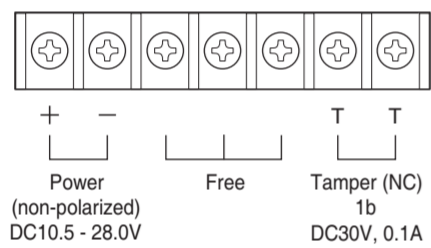

### 2. Wiring Length

Wire gauge	Maximum wiring distance (m)					
	NR30TM		NR60TM		NR90TM	
	DC12V	DC24V	DC12V	DC24V	DC12V	DC24V
AWG22 or $\phi 0.65$	140	1260	120	1080	110	990
AWG19 or $\phi 0.90$	270	2430	240	2160	220	1980
AWG16 or $\phi 1.20$	490	4410	440	3960	410	3690

Each value in the above table represents the maximum wiring distance (one way) when DC12V or DC24V power source is used. When installing 2 or more sets on one wire, the maximum length is obtained by dividing the maximum wire length given above by the number of sets installed. When using a thicker than AWG19 or  $\phi 0.9$  wire, use relays for connection. It is not possible to connect directly to the terminal inside of the detector.

### 3. Example

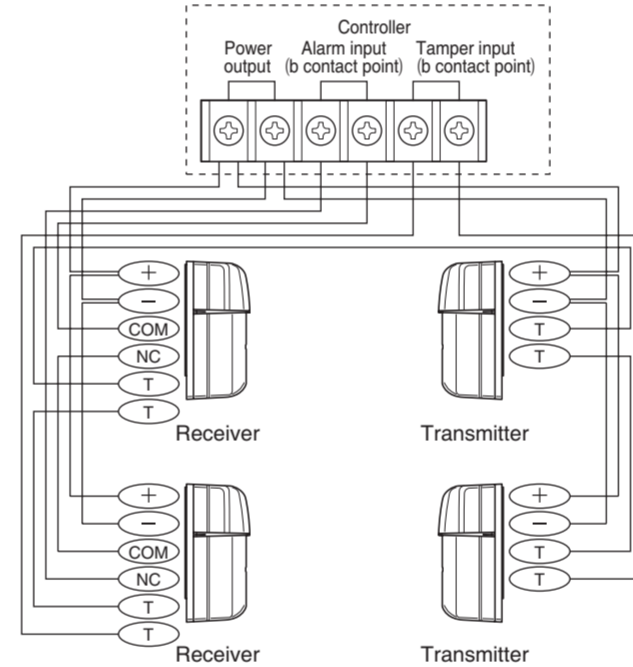

### CAUTION

Do not use aerial wiring, or malfunction may result.  
Be sure to cover outdoor wiring with pipes, or an electrical shock or failure may occur.  
Be sure to turn off the power during the wiring work, or an electrical shock or failure may occur.

## 4 COMPONENTS

The unit consists of the following major components

PARTS	PCS
Transmitter	1
Receiver	1
Installation manual	2

PARTS	PCS
$\phi 4$ tapping screw	4
Mount plate	2
Mount bracket	2

## 5 INSTALLATION

### ● WALL MOUNT

#### 1. Fasten the chassis.

Drill installation holes as shown dimension, install screws and fasten the chassis onto the wall.

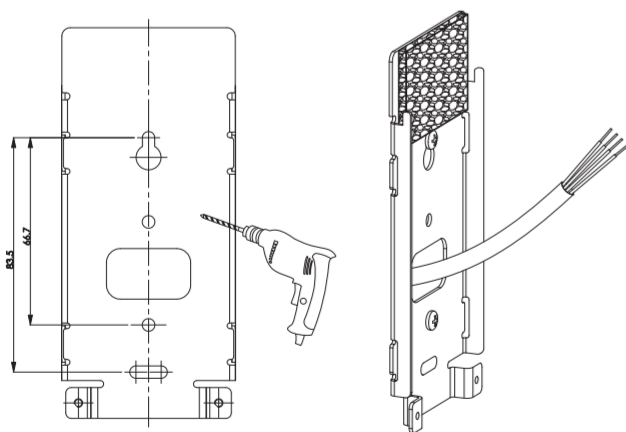

#### 2. Open the sensors.

Loosen screws in counterclockwise direction and then remove the cover.

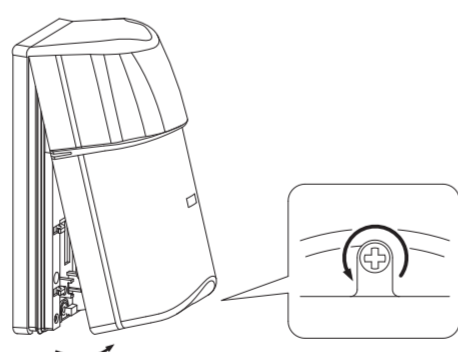

#### 3. Pull the wire through.

Press the sponge and pull the wire through.

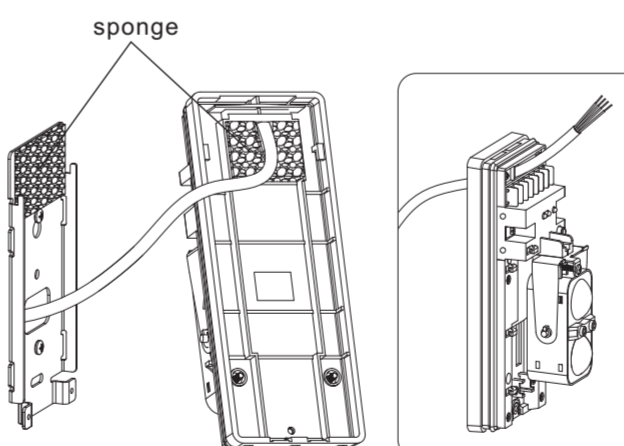

#### 4. Attach the sensors with chassis.

Install the sensors to the chassis following the arrow direction and then fasten the screws.

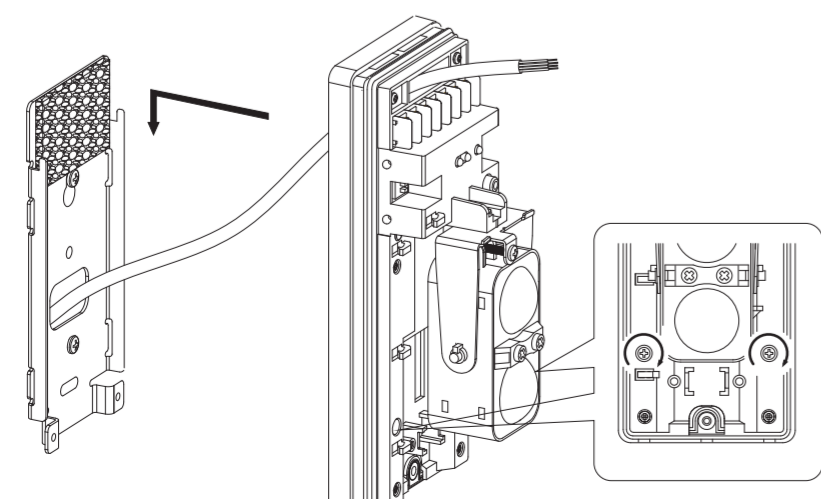

#### 5. Close the sensors.

Fasten screws in counterclockwise direction and then close the cover.

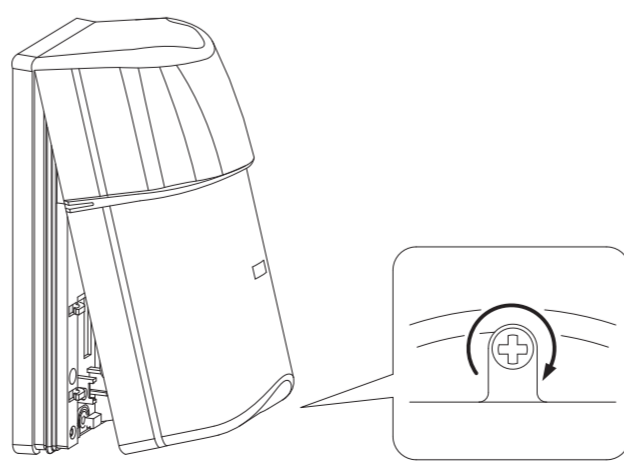

### ● POLE MOUNT

#### 1. Pull the wire through the wire hole of the pole.

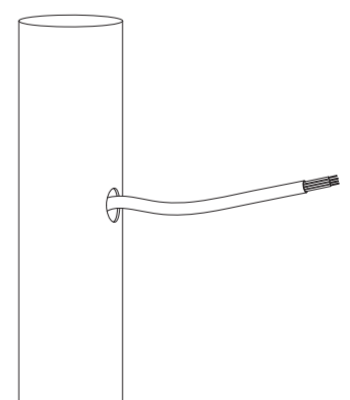

#### 2. Attach the bracket to the pole with the pole holder.

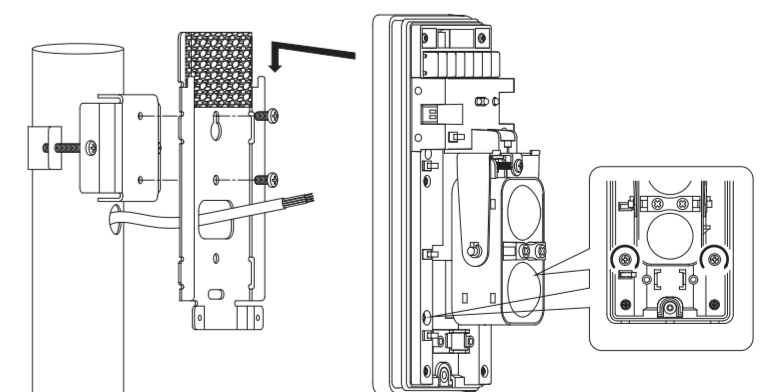

### CAUTION

Where there is not enough strength, perform full reinforcement work before installing the detector. If installed where not strong enough, the detector may drop, possibly resulting in its failure or damage and personal injury.

## 6 SENSITIVITY ADJUSTMENT

It is possible to adjust the detection sensitivity by adjusting the interruption time adjustment volume.  
When the unit is mounted on a wall, the interruption time can be set longer because the intruder cannot move quickly. This way, it is possible to prevent an erroneous operation by a bird, small animal, paper and other object that flies in.  
Adjust the sensitivity with the moving speed of a possible intruder taken into consideration. Also, be sure to check the unit for operation after adjustment.

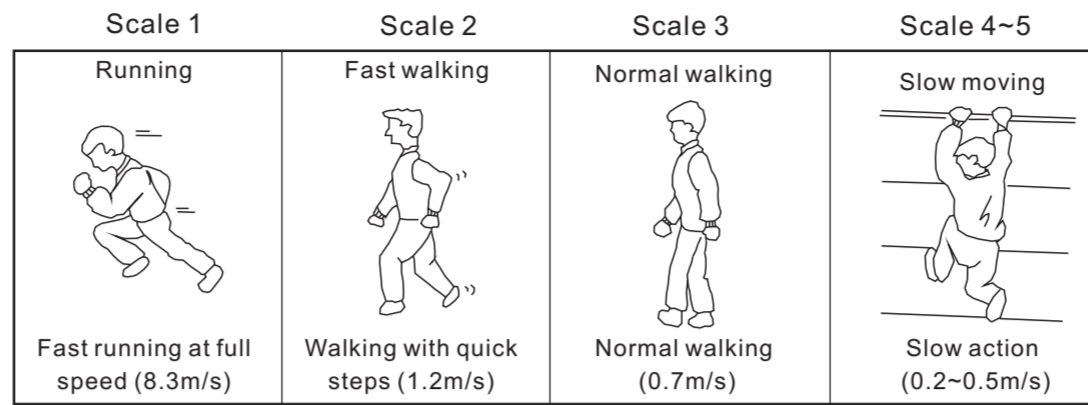
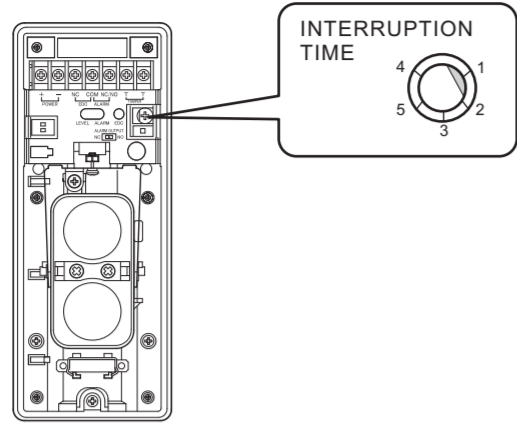

## 7 OPERATION CHECK

- Alarm Operation**  
To check the alarm operation, actually walk along assumed intrusion path near the transmitter and receiver, respectively and in-between as shown in the figure below.  
Check that the alarm LED lights up and the controller receives the alarm signal when the beam is interrupted.

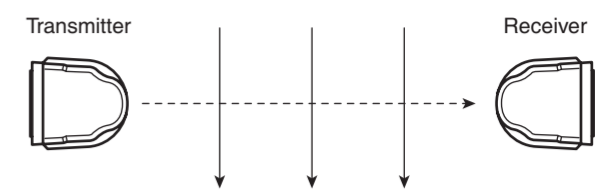

- Tamper Operation**  
Check that the controller receives an abnormal signal when either of the transmitter and receiver cover is open.

## 8 OPTICAL AXIS ALIGNMENT

There are two ways for optical axis alignment, by using a level LED and a tester.

### 1. Selectable Beams

Crosstalking will occur when using multiple beams for stack beam or long distance application, which can cause no-alarm problems. This NRXXTM series has selectable beams up to 4 channel which can be used to avoid crosstalking.

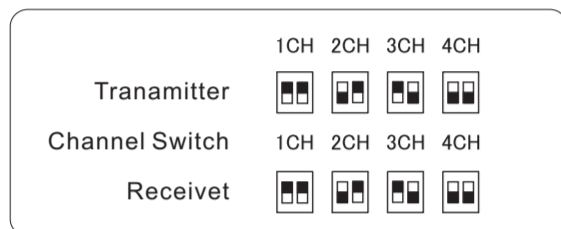

### 2. Using a level LED

**Rough adjustment**  
While looking into the scope located in the center of the lens 10 to 15cm away from it, turn the turntable for adjustment in the horizontal direction and the vertical adjustment screw for adjustment in the vertical direction until the detector on the other side is in the center of the scope as shown in the scope view shown below.  
Rough adjustment is OK when level LED turn off.

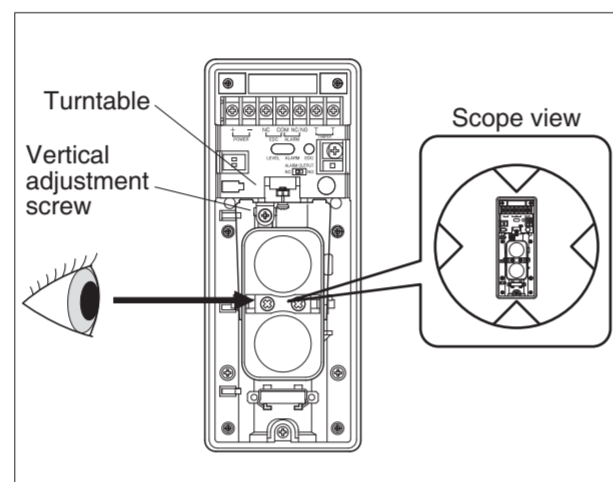

### 3. Using a tester

**Fine adjustment**  
Insert the tester stick into the tester hole in the receiver to check the tester voltage.  
If the measured value is 0.81V or more, adjustment is completed.  
If it is less than 0.81V adjust the horizontal and vertical adjustment screws of the transmitter and receiver until 0.81V or more voltage is obtained. (0.81V~ : good 0.84V~ : excellent)

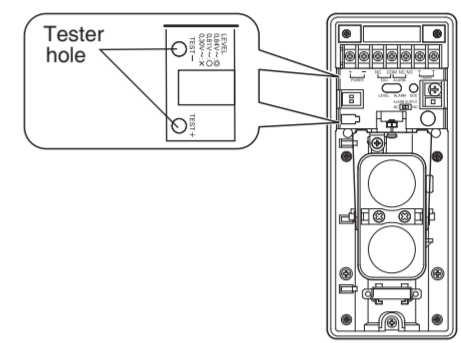

- Examples of the installation as below.

To avoid the mutual interference of beams, please set the beams at different channels, when installing more than one pairs at the same time.  
TR: Transmitter; RE: Receiver

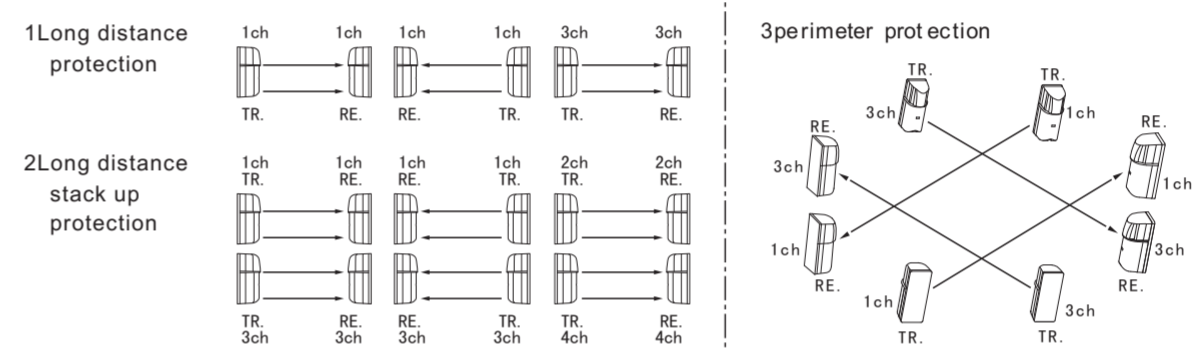

## 9 TROUBLESHOOTING

Problem	Possible cause	Solution
False alarm is output frequently.	An obstacle exists between transmitter and receiver.	Remove obstacle.
	Optical axis alignment is incomplete.	Perform optical axis alignment again to obtain 0.81V or more tester level.
	Installation condition is unstable.	Stabilize installation condition.
	Distance between transmitter and receiver exceeds rated distance.	Change installation position or use other detector with suitable rated distance.
	Beam is interfered with beam from another detector.	Take proper measure to avoid beam interference.
	There is an electrical noise source in nearby area.	Change installation position
	Sunlight enters receiver within $\pm 3^\circ$ angle.	Replace transmitter and receiver.
No alarm is output even when beam is interrupted	There is a highly reflective wall in parallel with beam.	Adjust optical axis so that it is on the other side of reflection surface.
	Reflectance of floor surface is high.	Adjust optical axis so that it is on the other side of reflection surface.
	Beam is interfered with beam from another detector.	Take proper measure to avoid beam interference.
	Height of installation position is inappropriate.	Change installation position to a proper height.

**-Note-**  
If the trouble remains unsolved even after taking above solution, please consult the dealer of your purchase.

## 10 SPECIFICATIONS

Product Name	Photoelectric Detector		
	NR30TM	NR60TM	NR90TM
Model	NR30TM	NR60TM	NR90TM
Power	DC10.5V~28V		
Current Draw	Transmitter : 15mA(at 25°C)	Transmitter : 24mA(at 25°C)	Transmitter : 31mA(at 25°C)
	Receiver : 64mA(at 25°C)	Receiver : 64mA(at 25°C)	Receiver : 64mA(at 25°C)
Operating Temp./Humid	-25°C~+55°C, RH 95%or less		
Storage Temp./Humid	-30°C~+60°C, RH 95%or less		
Alarm Output	Alarm	Form 1a.1b Selectable relay (DC30V, 0.1A) Output Period: 1.0 sec.	
	EDC	Form 1b relay (DC30V, 0.1A)	
	Tamper	Form 1b relay (DC30V, 0.1A) Retention time: While cover is opened	
Max. Coverage	30m	60m	90m
Sensitivity	30 msec. ~ 900m sec. (Selectable)		
Lens Movable Range	Horizontal direction: $\pm 90^\circ$ / Vertical direction: $\pm 5^\circ$		
Installation Site	Indoor / Outdoor(IP55)		
Weight	Transmitter: about 380g / Receiver: about 380g		
Color	Black Mansel approximation N1.0		

## 11 DIMENSIONS

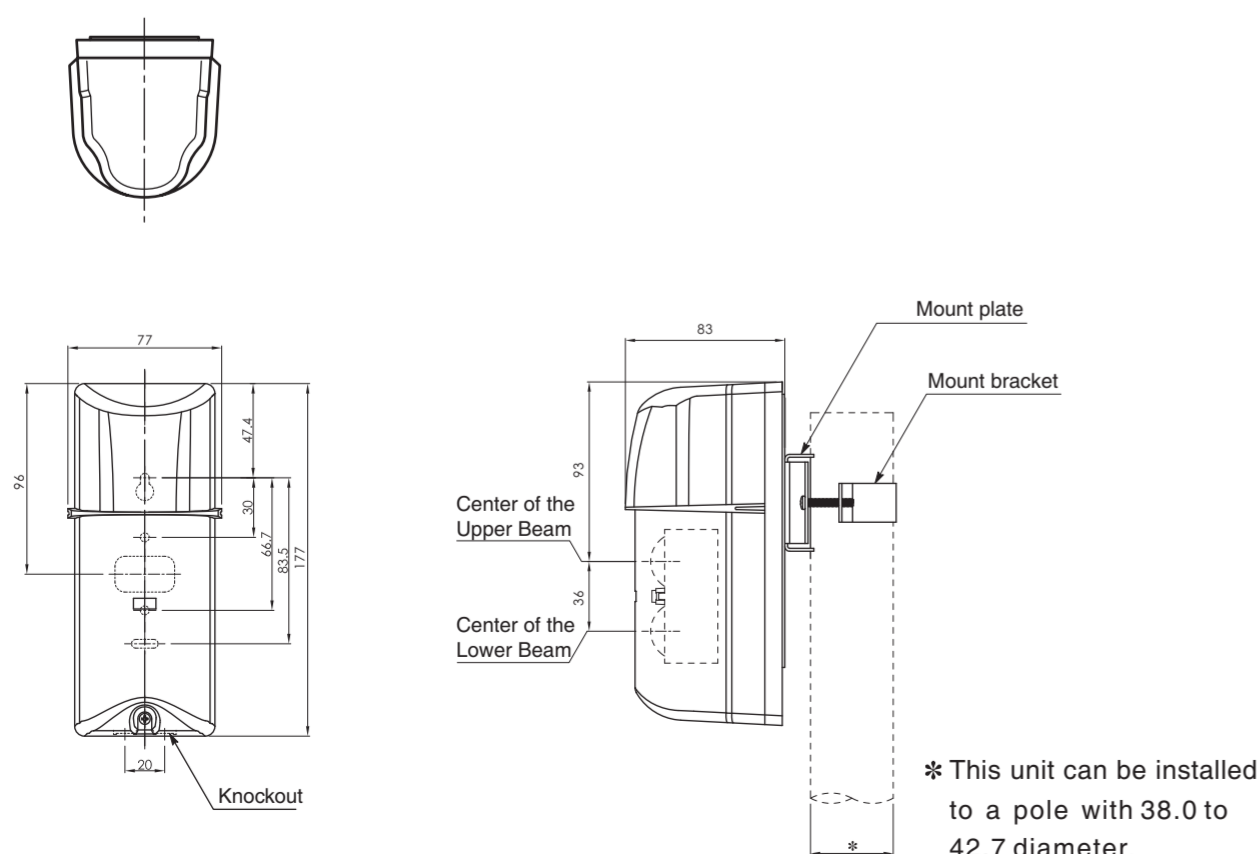

## 12 MAINTENANCE

- Be sure to perform periodical inspection at least annually.
- Check items
    - Tester level: Check that the tester level is 0.81V or more.
    - Power input voltage: Check that DC 10.5V to 28V is obtained.
    - Operation: Referring to **7** OPERATION CHECK, check alarm operation and tamper operation.

**ATSUMI ELECTRIC CO., LTD.**  
4-2-2 Shin-Miyakoda, Hamamatsu, Shizuoka 431-2103 Japan  
Phone: +81-53-428-4116 Fax: +81-53-428-4119